



## GENERAL DESCRIPTION

- **Revo S has been specifically designed to save space and labour**
- These simple units can be connected with REVO PC to manage multizone system this minimize your energy cost by controlling synchronization and power limit on each zone
- All circuit board, Fuses and Thristor can be inspected just opening the front door
- Input signal: SSR, Analog as an option
- Zero Crossing, Burst Firing available at 4, 8 or 16 Cycles at 50% of Power demand
- Electronic fully isolated from power with constant current drain on input.
- Heater Break alarm option to diagnose partial or total load failure and Thyristor Short circuit
- Fixed Fuse are available as a standard
- Current transformer integrated (with Heather Break option)
- Special design for Heat sink with very high dissipation value
- Comply with EMC, cUL (pending)
- DIN RAIL side by side mounting
- IP20 Protection

## TECHNICAL SPECIFICATION

<b>Voltage power supply</b>	24V minimum up to 480V, 600V On request		
<b>Voltage Frequency</b>	50 or 60 Hz no setting needed from 47 to 70 Hz		
<b>Nominal Current</b>	60A, 90A, 120A, 150A, 180A, 210A		
<b>Input Signal</b>	SSR for REVO S, No Fuse,	5:30Vdc	18mA Max (On ≥ 5Vdc Off ≤ 4Vdc);
	SSR for REVO S, Fuse + Fuse Holder	7:30Vdc	18mA Max (On ≥ 7Vdc Off ≤ 6Vdc);
	SSR for REVO S, Fuse + Fuse Holder,+ HB	4:30Vdc	6mA Max (On ≥ 4Vdc Off ≤ 1Vdc);
	Voltage input	0:10Vdc	impedance 15 K ohm;
	Current input	0:20/4:20mA	impedance 100 Ohm;
<b>Firing</b>	Zero Crossing, Burst Firing with analog input signal only		
<b>Auxiliary Voltage Supply</b>	12:24V dc/ac (max 70 mA) required only with HB Alarm or Analog Input Option		
<b>Heater Break Alarm</b>	Microprocessor based with automatic setting via Digital Input; Relay Output 0,5A at 110V		
<b>Mounting</b>	Panel mounting		
<b>Operating Temperature</b>	40 °C without derating. Over this temperature see below derating curve		
<b>Storage temperature</b>	-25 °C to 70 °C Max		
<b>Altitude</b>	Over 1000 m of altitude reduce the nominal current of 2% for each 100m		
<b>Humidity</b>	From 5 to 95% without condense and ice		

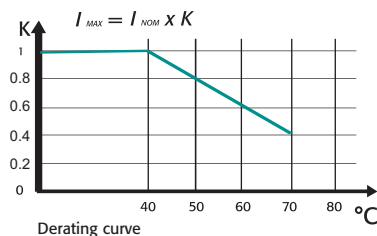

## OPTION'S FEATURES AND SPECIAL DETAILS

### HEATER BREAK ALARM (HB)

#### ON FRONT CABINET



FEW SECOND TO SET AND CALIBRATE ALL THE UNITS

- Microprocessor based circuit
- Capacity to diagnose the failure of one Resistance over five in parallel
- Load failure alarm with LED indication on front unit
- Thyristor short circuit alarm with LED indication on front unit
- Alarm output with free voltage relay contact
- Alarm reset function and possibility to auto reset if the alarm disappear
- Built in Current transformer when heater Break option has been selected
- Self Setting via external command or push button on front unit
- Common setting command can be given to many units and in a matter of second, the tuning is done, also by a non expert operator

### HOW TO ADD POWER LOAD MANAGEMENT AND FEATURES TO YOUR SIMPLE UNITS

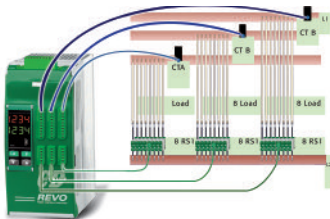

APPLICATION WITH 8, THREE PHASE LOADS

Use REVO-PC and you can add these Features

- Communication with different field bus
- Reading of current Voltage and Power
- Instantaneous power very close to average value, no pick power
- Power factor close to one no harmonics
- Prevents increase in energy supply tariffs imposed by your electricity supplier

#### Synchronization

On all controlled zones, REVO-PC Synchronization is automatic resulting in superior performance:

- Total current is equal to a sinusoidal wave form.
- Power factor > 0,9.
- Instantaneous current close to average value.
- Cancellation of harmonics.
- Flickering effect removed.

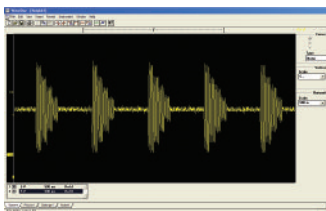

WITHOUT POWER CONTROL OPTIMISATION

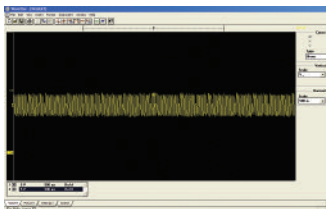

WITH POWER CONTROL OPTIMISATION

#### Smart power limitation

- Smart power limitation works together with synchronization. If this function is enabled, REVO-PC makes a live calculation of power at each period and generates the output values for the next period. If the calculated power is below the power limit value, the previous values remain with each channel using full power.
- If the power is above the power limit value, the setpoint of each channel is reduced proportionally to restrict power overshoot. This function significantly reduces disturbances on the main network compared to a full power system, preventing any increase in energy tariffs imposed by the electricity supplier.
- This function can be activated/deactivated and the limit value changed at any time.

### ORDERING CODES REVOS PC

	1	2	3	4	5	6	7	8	9	10	11	12	13	14	15	16	
<b>REVO-PC</b>	<b>R</b>	<b>P</b>	<b>C</b>	-	-	-	-	-	-	-	-	-	-	-	<b>0</b>	<b>0</b>	<b>0</b>
<b>4,5 Channels</b>	<b>Description code</b>		<b>Numeric code</b>														
	8 Channels (for 8 Off one phase unit)			0 8													
	16 Channels (for 16 Off one phase unit)			1 6													
	24 Channels (for 24 Off one phase unit)			2 4													
	8 Channels for 2-3PH			3 8													
<b>6 Current Sensor</b>	<b>Description code</b>		<b>Numeric code</b>														
	50/0,05 A			1													
	100/0,05 A			2													
	150/0,005 A			3													
	200/0,05 A			4													
	250/0,05A			5													
	400/0,05A			6													
	80070,05A			7													
<b>7 Communication</b>	<b>Description code</b>		<b>Numeric code</b>														
	Ethernet			1													
	ModBus Slave			2													
	ModBus Master			3													
	Profibus			4													
	Profinet			5													
<b>8 Primary Voltage Aux. Transformer</b>	<b>Description code</b>		<b>Numeric code</b>														
	Transformer 24V			1													
	90:130V			2													
	170:265V			3													
	230:345v			4													
	300:530V			5													
	510:690V			6													
	600:760V			7													
<b>9 Firing</b>	<b>Description code</b>		<b>Numeric code</b>														
	Half Cycle at 50% power demand			1													
	One Cycle at 50% power demand			2													
<b>10 Feed Back</b>	<b>Description code</b>		<b>Numeric code</b>														
	No feedback			1													
	Power			2													
<b>11 Approvals</b>	<b>Description code</b>		<b>Numeric code</b>														
	CE EMC			1													
<b>12 Manuals</b>	<b>Description code</b>		<b>Numeric code</b>														
	None			0													
	Italian Manual			1													
	English Manual			2													
	German Manual			3													
	French Manual			4													
<b>13 Version</b>	<b>Description code</b>		<b>Numeric code</b>														
	Version 1			1													

# WIRING CONNECTION REVO S 2PH from 60A to 210A

## CD3000S 2PH from 60 to 90A

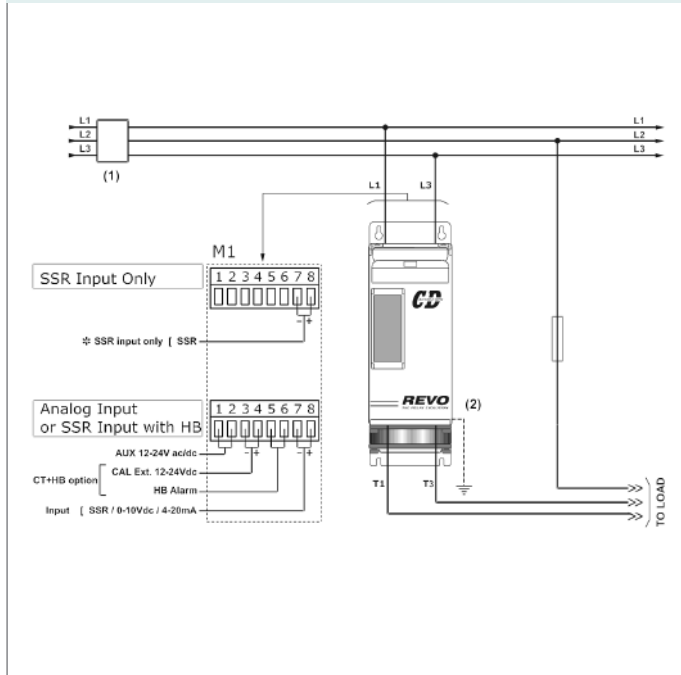

## REVO S 2PH from 120 to 210A

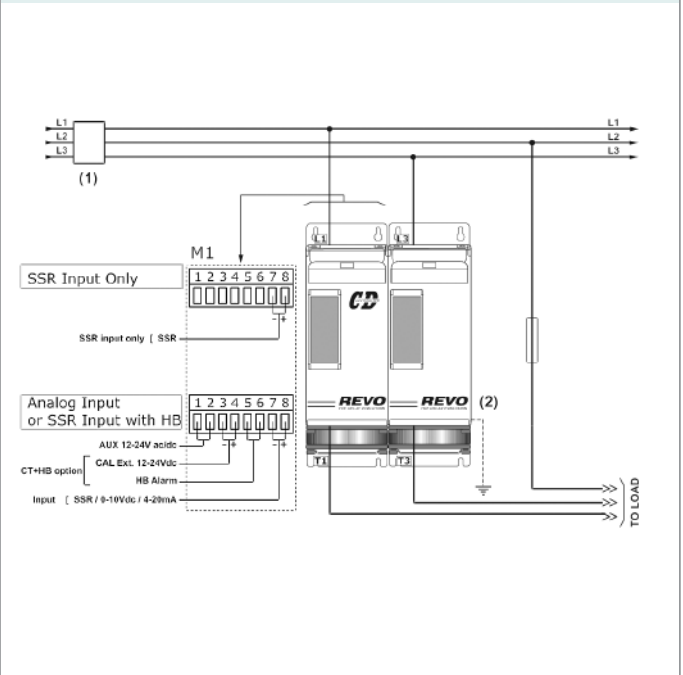

### LOAD TYPE

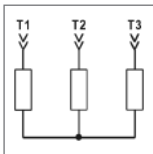

STAR without neutral  
Resistive or  
Infrared Lamps  
Long and  
medium waves

### LOAD TYPE

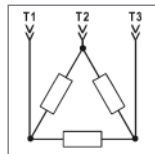

DELTA  
Resistive or  
Infrared Lamps  
Long and  
medium waves

### NOTE

- A suitable device must ensure that the unit can be electrically isolated from the supply, this allows the qualified people to work in safety.
- The user installation must be protecting by electromagnetic circuit breaker or by fuse isolator. The semiconductor fuses are classified for UL as supplementary protection for semiconductor.
- The heat-sink must be connected to the earth.

## DIMENSION AND FIXING HOLES

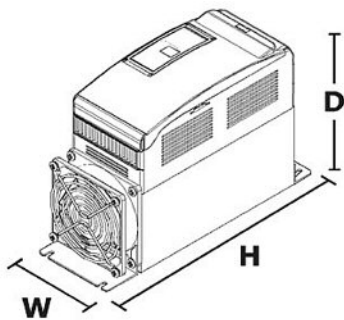

**SR15** W 93 mm. - H 273 mm. - D 170 mm. - kg. 3,6

**60A - 90A**

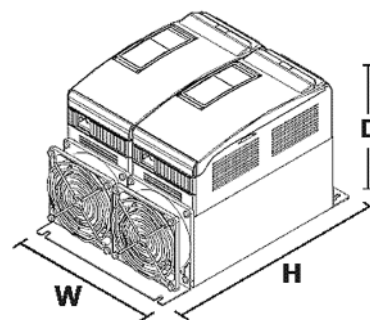

**SR16** W 186 mm. - H 273 mm. - D 170 mm. - kg. 7

**120A ÷ 210A**

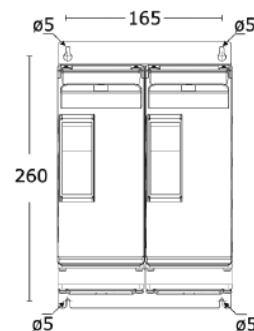
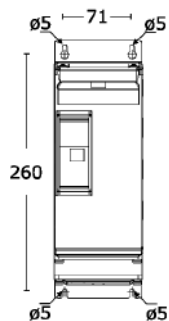

## OUTPUT FEATURES (POWER DEVICE)

Current A	Voltage range (V)	Ripetitive peak reverse voltage (480V) (600V)		Latching current (mAeff)	Max peak one cycle (10msec.)	Leakage current (mAeff)	I2T value for fusing tp=10msec.	Frequency range (Hz)	Power loss I=Inom (W)	Isolation Voltage Vac
60A	24+600V	1200	1600	450	1000	15	4750	47÷70	130	2500
90A	24+600V	1200	1600	450	2000	15	19100	47÷70	168	2500
120A	24+600V	1200	1600	450	1540	15	11300	47÷70	276	2500
150A	24+600V	1200	1600	450	2000	15	19100	47÷70	324	2500
180A	24+600V	1200	1600	300	4800	15	108000	47÷70	356	2500
210A	24+600V	1200	1600	300	5250	15	128000	47÷70	404	2500

## FAN SPECIFICATION

Supply: 230V Standard	Input Power 16W
Supply: 115V Option	Input Power 14W

## ORDERING CODES REVOS 2PH

	1	2	3	4	5	6	7	8	9	10	11	12	13	14	15	16
<b>REVO S - 2PH</b>	<b>R</b>	<b>S</b>	<b>2</b>	-	-	-	-	-	-	-	-	-	-	-	-	-

4, 5, 6 Current	
Description code	Numeric code
60A	0 6 0
90A	0 9 0
120A	1 2 0
150A	1 5 0
180A	1 8 0
210A	2 1 0

7 Max Voltage	
Description code	Numeric code
480V	4
600V	6

8 Aux. Voltage supply	
Description code	Numeric code
No Aux. Voltage, without HB and/or without Analog Input	0
12:24V ac-dc 70mA, with HB and/or Analog Input	4

9 Input	
Description code	Numeric code
SSR	S
0:10V dc	V
4:20mA	A

10 Firing	
Description code	Numeric code
Zero Crossing ZC	Z
Burst Firing 4 Cycles On at 50% Power Demand	4 (1)
Burst Firing 8 Cycles On at 50% Power Demand	8 (1)
Burst Firing 16 Cycles On at 50% Power Demand	6 (1)

11 Control Mode	
Description code	Numeric code
Open Loop	0

12 Fuse & Option	
Description code	Numeric code
Fixed Fuses IF	F
Fixed Fuses +CT	Y
Fixed Fuses +CT +HB	H

13 Fan Voltage	
Description code	Numeric code
No Fan ≤ 90A	0
Fan 110V > 90A	1
Fan 220V > 90A Std Version	2

**LEGEND**  
**IF** = Internal Fixed Fuse  
**CT** = Current Transformer  
**HB** = Heater Break Alarm

**Note (1):** Available only with Analog input

14 Approvals	
Description code	Numeric code
CE EMC For European Market	0
cUL For American Market, pending	L

15 Manual	
Description code	Numeric code
None	0
Italian Manual	1
English Manual	2
German Manual	3
French Manual	4

16 Version	
Description code	Numeric code
Std with fixed Fuses	1

